

SELECTION CRITERIA

- Fresh water use
- Direct acting
- Actuation by pressure
- Open on pressure increase
- 150 PSI water pressure rating
- Optional open on pressure decrease
- Union end connections NPT
- 2-way configuration
- 3/8" thru 1-1/4" sizes
- Optional use of ammonia
- 225 PSI proof pressure

CONSTRUCTION DETAILS

- Brass & Stainless Steel internals
- Buna-N diaphragms & seals
- Brass body

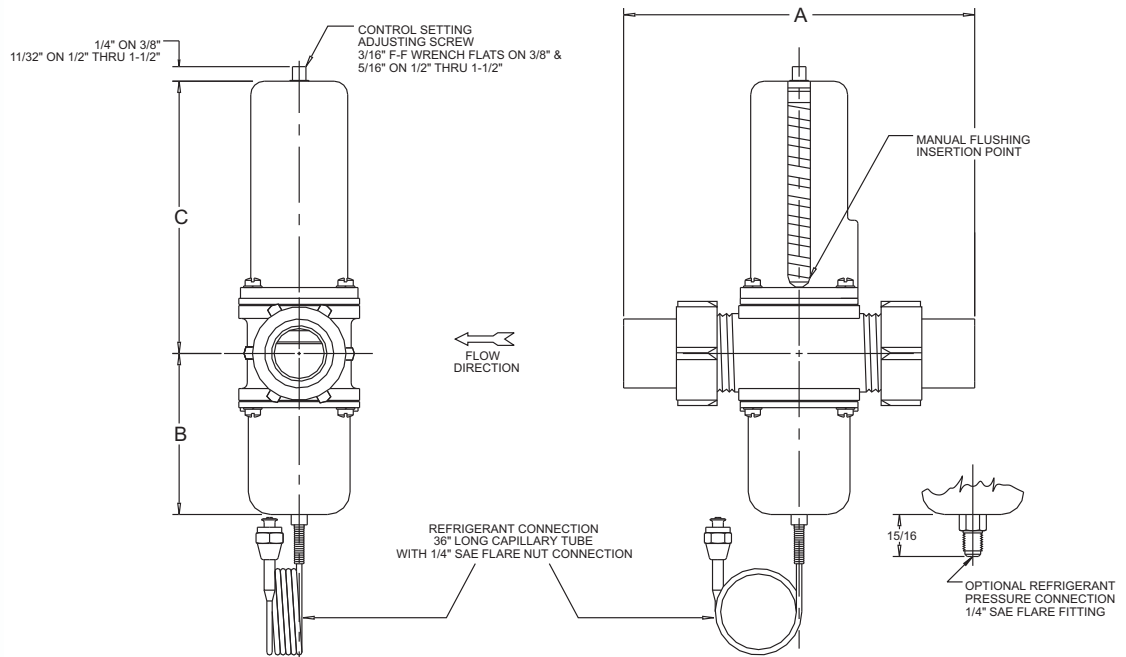

Reference Metrex drawing 800P-UE

VALVE SIZING CHART

VALVE PART NUMBER	PIPE SIZE	C _v	DIMENSIONS		
			A	B	C
800P-37UE	3/8"	2.3	4-9/16"	2-5/32"	3-7/32"
800P-50UE	1/2"	3	5"	2-5/8"	3-21/32"
800P-75UE	3/4"	5	5-7/16"	2-3/4"	3-13/16"
800P-100UE	1"	7	6-13/16"	3-21/32"	6-3/16"
800P-125UE	1-1/4"	13	7-7/16"	3-13/16"	6-5/16"

ORDERING INFORMATION

- Use the Valve Sizing Chart on the preceding page tables and charts below to determine the complete part number.

BASIC PART NO.: 800P - -UE

BELLOWS OPTIONS
VALVE SIZING CHART

PRESSURE RANGE ADJUSTMENT

- The refrigerant pressure at which the valve begins to open can be adjusted from 50 to 225 PSI. A 45 PSI increase of pressure is required to open the valve fully.

BELLOWS OPTIONS

- The Optional ammonia actuator includes a steel assembly and is designated by an "A" after the P.

Example: 800PA-100-UE.

The Optional reverse acting configuration (closes on a pressure increase) is designated by an "R" after the P.

Example: 800PR-37-UE.

The Optional 1/4" male SAE flare fitting for refrigerant pressure connection is designated by an "F" after the P. The 1/4" SAE flare fitting replaces the 36" long capillary tube with 1/4" SAE flare nut connection.

Example: 800PF-100-UE.

VALVE FLOW DATA

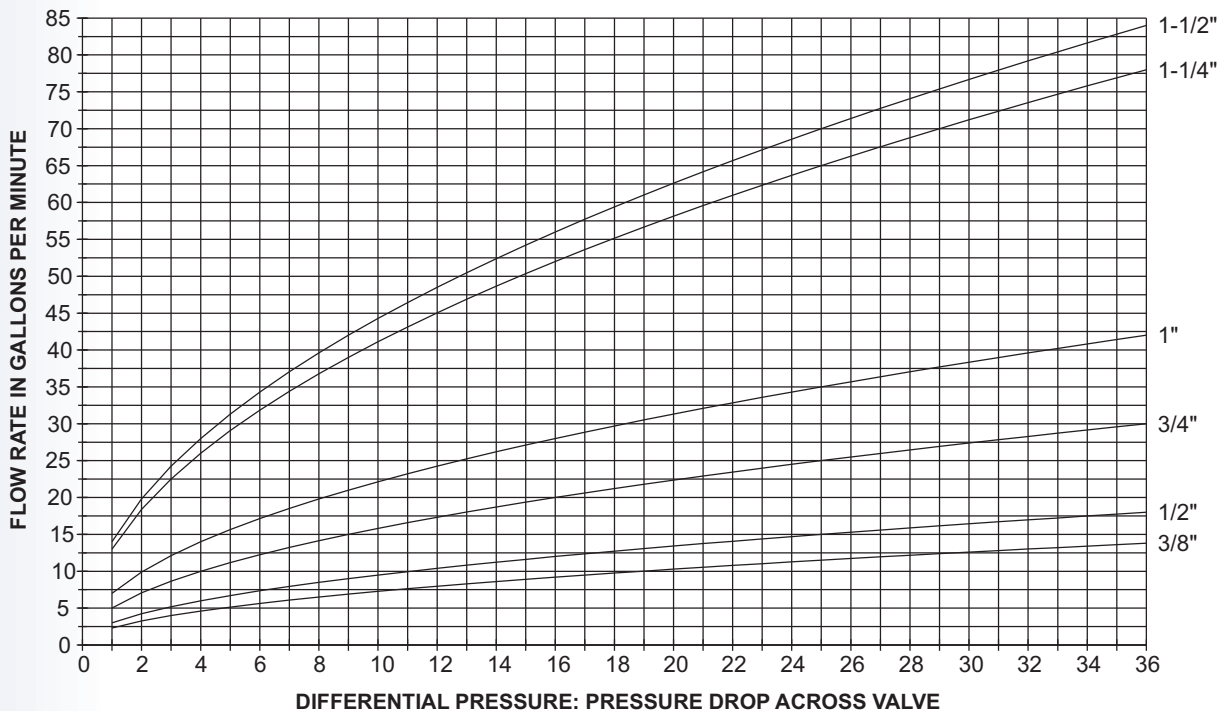

2-WAY HEAD PRESSURE REGULATOR TYPICAL APPLICATION

PAGE 3 OF 3

- Typically used to modulate the cooling water through a condenser in response to a pressure signal from the condenser. Refrigerant head pressure is maintained over a wide range of operating conditions for a maximum system operating efficiency.

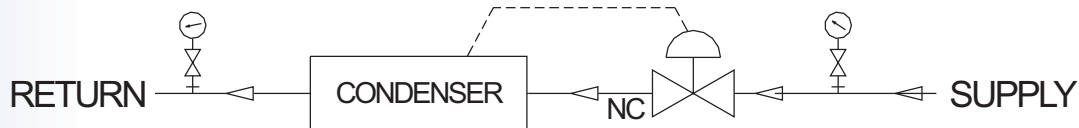

INSTALLATION INSTRUCTIONS

- Valves can be mounted in any position without affecting performance. However, for ease of adjustment consider the accessibility of the adjusting screw.
- Connect the incoming water line to the valve inlet. Direction of water flow (see drawing) is indicated by the arrow cast on the side of the valve body.
- Connect capillary tube (1/4" flare nut) to refrigerant head pressure connection on condenser.

GENERAL DESCRIPTION

- The 800 series valves are direct acting, modulating water regulating valves utilizing a diaphragm construction to give a smooth, well balanced action. The pressure-balanced design and low frictional co-efficient of the diaphragm assure fast response to changes in refrigerant pressure and protection against both gradual and sudden water pressure changes. All sliding parts and adjustment springs are isolated from the water flow by the leak proof diaphragms.

ADJUSTMENT

- All valves in 3/8" through 1-1/4" sizes are multi-range valves applicable to both R-12 and R-22 service. The refrigerant pressure at which the valve begins to open can be adjusted from 50 to 225 PSI. A 45 PSI increase of pressure is required to open the valve fully.

To adjust condensing head pressure, use wrench or pin and turn adjusting screw on top of the spring housing. Turn to the right (counter clockwise) to raise the opening point and the left (clockwise) to lower.

MANUAL OVERRIDE

- All valves may be manually flushed by inserting a screwdriver in openings at opposite sides of the spring housing and lifting the lower spring plate to open the valve. The valve adjustment is not affected by manual flushing.