

## SELECTION CRITERIA

- Marine water use
- Pilot operated
- Actuation by pressure
- Open on pressure increase
- 150 PSI water pressure rating
- Flanged end connections
- 2-Way configuration
- 6" & 8" sizes
- Optional use of ammonia
- Optional low pressure refrigerants
- 225 PSI proof pressure

## CONSTRUCTION DETAILS

- Bronze & Monel internals
- Buna-N diaphragms & seals
- Bronze body per ASTM B62
- Flange: ANSI B16.24 150#.
- Optional MIL-F-20042 250# Flanges

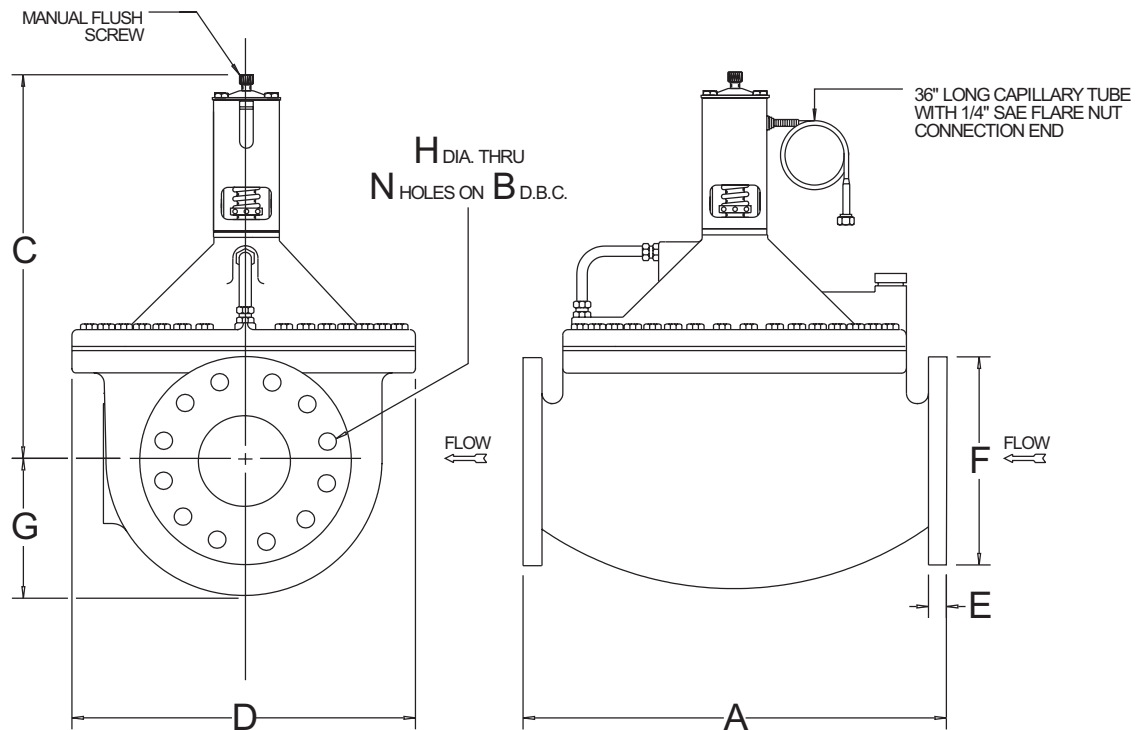

Reference Metrex drawing YM-3145C-MF & YM-3170C-MF

## VALVE SIZING CHART

VALVE PART NUMBER	PIPE SIZE	C <sub>v</sub>	DIMENSIONS						FLANGE DATA			APPROX. SHIP WT.
			A	C	D	E	F	G	B	N	H	
YM-3145C-MF-2W	6"	SEE TABLE 1	20"	15-25/32"	15-1/2"	13/16"	11"	6-13/16"	9-1/2"	8	7/8"	340#
YM-3170C-MF-2W	8"	SEE TABLE 1	25-1/2"	22-7/8"	19-7/8"	15/16"	13-1/2"	10-1/8"	11-3/4"	8	7/8"	680#

## ORDERING INFORMATION

- Use the valve sizing chart on the preceding page tables and charts below to determine the complete part number.

**BASIC PART NO.: YM -3- C-MF-2W-**

BELLOWS OPTIONS  
VALVE SIZING CHART  
TABLE I

## BELLOWS OPTIONS

- The optional ammonia actuator is designated by an "A" after the M.

Example: YMA-3145C-MF-2W.

The optional 1/4" male SAE flare fitting for refrigerant pressure connection is designated by an "F" after the M. The 1/4" SAE flare fitting replaces the 36" long capillary tube with 1/4" SAE flare nut connection.

Example: YMF-3145C-MF-2W.

Actuators are available for R-11 & R-114 applications. Please call factory for more information.

## PRESSURE RANGE ADJUSTMENT

- The refrigerant pressure at which the valve begins to open can be adjusted from 70 to 260 PSI. A 25 PSI increase of pressure is required to open the valve fully. Consult Factory for optional low pressure refrigerants. Minimum required differential pressures are listed in TABLE 1.

## TRIM SELECTION

- TABLE 1 shows Cv for available trim for each size valve. If no trim is specified, TA trim is provided.

VALVE PART NUMBER	TRIM DESIGNATOR	PIPE SIZE	C <sub>v</sub>	MIN. Δ P
YM-3145C-MF-2W-TA	TA	6"	290	4 PSI
YM-3145C-MF-2W-TB	TB	6"	180	4 PSI
YM-3145C-MF-2W-TC	TC	6"	110	4 PSI
YM-3145C-MF-2W-T1	T1	6"	245	4 PSI
YM-3170C-MF-2W-TA	TA	8"	720	5 PSI

## VALVE FLOW DATA

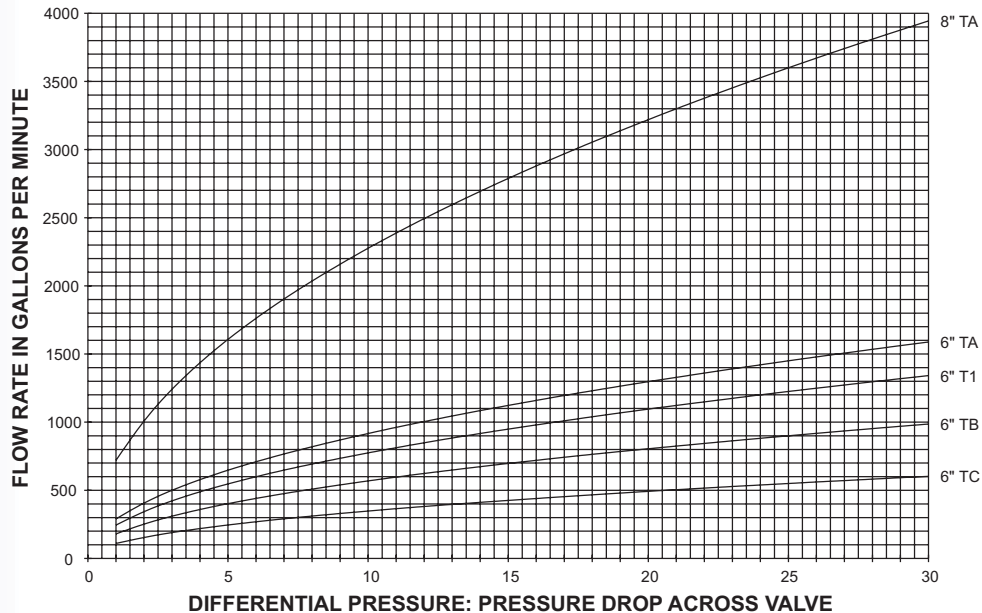

NOTE: A pressure differential across the valve of no less than 4 PSI is required.

## INSTALLATION INSTRUCTIONS

PAGE 3 OF 3

- 1) All valves should be mounted vertically on a horizontal water line.
- 2) Connect the incoming water line to the valve inlet. Direction of water flow (see drawing) is indicated by the arrow cast on the side of the valve body. Connect downstream water line to valve outlet.
- 3) Connect capillary tube (1/4" flare nut) to refrigerant head pressure connection on condenser. Note: For ammonia service, steel bellows assembly with 1/4" male flare connection furnished in lieu of capillary tube.

## 2-WAY HEAD PRESSURE REGULATOR TYPICAL APPLICATION

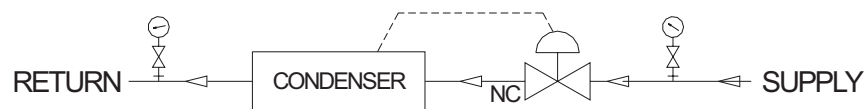

## OPERATION INSTRUCTIONS

- 1) Start incoming water flow and the system water will flow through the external tubing into the chambers above the diaphragm. The force exerted by the upper diaphragm, due to the larger effective area, will overcome that acting against the valve seat and the valve will close.
- 2) To flush the valve through condenser outlet, independent of head pressure setting, insert an allen wrench into the manual flush screw and turn clockwise until the screw bottoms. After flushing, reverse this procedure for automatic operation. Caution: If the screw is not unscrewed or backed off sufficiently to clear the top plate on the bellows housing after flushing, the valve will not close.
- 3) To open the valve, sufficient actuating head pressure is required to overcome the tension on the power spring. The YM model is a multi-range valve with refrigerant pressure range adjustable from 70-260 PSI. The valve controls the flow rate of water in response to changes in signal pressure (refrigerant pressure) to its pilot. The valve opens on increasing refrigerant pressure and closes on decreasing pressure. The refrigerant pressure acting upon the bellows exerts a force opposed by the power spring and modulating spring. Increasing refrigerant pressure overcomes the spring forces, and opens the pilot valve assembly. As the flow past the pilot valve exceeds the flow past the metering orifice or restrictor, the valve begins to open, compressing the modulating spring. As the modulating spring is compressed, its increased force reduces the pilot valve opening until the flow from the cover equals the flow into the cover. The main valve is now held at a fixed position that is determined by the refrigerant pressure. Decreasing refrigerant pressure results in the pilot valve lift decreasing, causing the valve to begin to close until the modulating spring force has decreased to match the change in refrigerant pressure bellows force. The "feedback" action of the modulating spring causes the main valve to hold a position proportional to the refrigerant pressure, and results in a very stable control valve allowing only the flow necessary for an efficient operating system.
- 4) To increase the actuating refrigerant head pressure, insert a pin or hex key into the adjustment nut and turn counter-clockwise. To lower actuating refrigerant head pressure, turn adjustment nut clockwise.

## MAINTENANCE INSTRUCTIONS

Water to the valve must be clean and free of foreign particles. If the water supply is dirty, a strainer should be installed upstream of the valve and cleaned as often as is necessary. Foreign particles, if carried through the pilot passages, may tend to obstruct the metering orifice or restrictor and prevent the valve from closing. External tubing including the metering

orifice or restrictor should be cleaned periodically.

It is recommended that the valve be disassembled and inspected for wear or corrosion at 12 to 18 month intervals, depending on service conditions. Complete rebuild kits are available from Metrex Valve.