

SELECTION CRITERIA

- Fresh water use
- Direct acting
- Patented 650 PSI rated actuator
- Open on pressure increase
- For R410a refrigerant applications
- Screwed end connections NPT
- 2-Way configuration
- 1-1/4" & 1-1/2" sizes
- 350 PSI water pressure standard
- Available water pressure to 500 PSI

CONSTRUCTION DETAILS

- Brass & stainless steel internals
- Buna-N diaphragms & seals
- Brass body

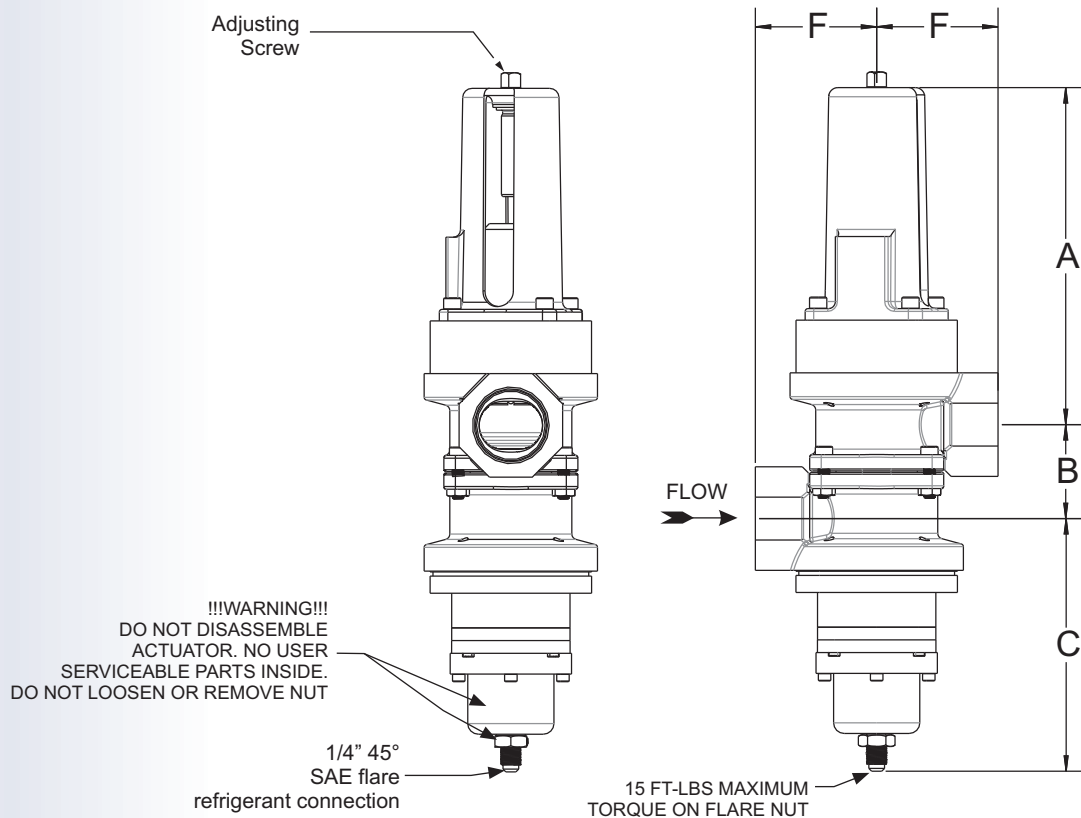

VALVE SIZING CHART

VALVE PART NUMBER	PIPE SIZE	C _v	DIMENSIONS				APPROX. SHIP WT.
			A	B	C	F	
565P-125_SE-2W	1-1/4"	14.5	7.29	2.03	5.46	2.63	15#
565P-150_SE-2W	1-1/2"	17	7.41	2.22	5.59	2.75	18#

All dimensions are in inches

ORDERING INFORMATION

- Use the valve sizing chart on the preceding page, tables, and charts below to determine the complete part number.

BASIC PART NO.: 565P- 1 - SE -2W

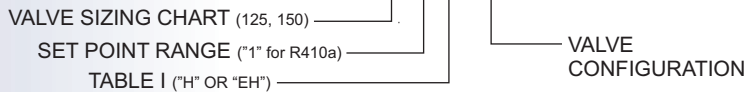

EXAMPLE: • "125" = 1-1/4" pipe size
565P-1251H-LRSE-2W • "1" = R410a range
• "H" = 450 PSI water pressure
• "LR" = Lower port to the right

PRESSURE RANGE ADJUSTMENT

- The refrigerant pressure range which the valve begins to open can be adjusted per table II. An approximate increase of refrigerant pressure (span) per Table II is required to open the valve fully.

SET POINT RANGE	ADJUSTMENT	SPAN
1	170-330	55
2	TBD	TBD

All pressures are PSIG

FLOW DATA

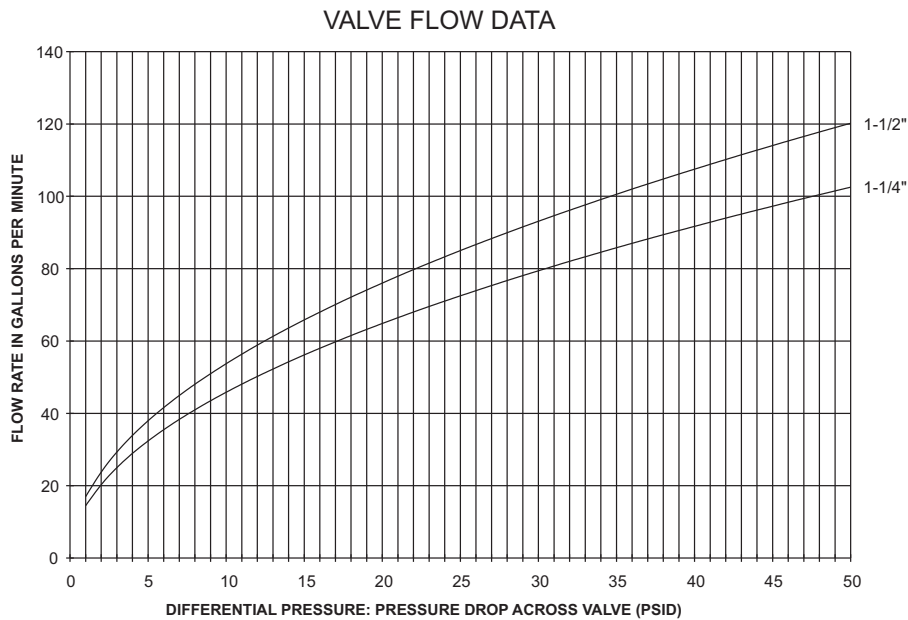

VALVE RATING & CONFIGURATION

WATER PRESSURE RATING	STANDARD	H	EH
DESIGN PRESSURE	350 PSI	450 PSI	500 PSI
PROOF PRESSURE	525 PSI	675 PSI	750 PSI

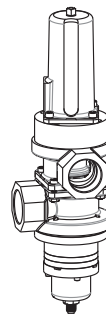

"LL"
LOWER PORT
TO LEFT

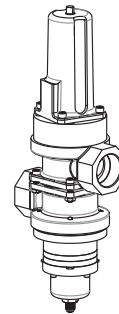

"BP"
BOTH PORTS
PARALLEL
(STANDARD)

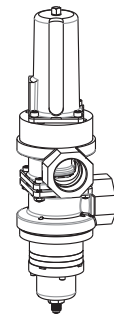

"LR"
LOWER PORT
TO RIGHT

2-WAY HEAD PRESSURE REGULATOR TYPICAL APPLICATION

PAGE 3 OF 3

- Typically used to modulate the cooling water through a condenser in response to a pressure signal from the condenser. Refrigerant head pressure is maintained over a wide range of operating conditions for a maximum system operating efficiency.

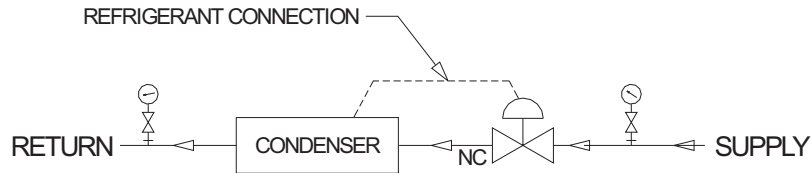

INSTALLATION INSTRUCTIONS

- Valves can be mounted in any position without affecting performance. However, for ease of adjustment consider the accessibility of the adjusting screw.
- Connect the incoming water line to the valve inlet. Direction of water flow is indicated by the arrow cast on the side of the valve body.
- Connect 1/4" male flare fitting on valve actuator to refrigerant head pressure connection on condenser. Use 1/4" copper refrigerant tubing, capillary tubing or other suitable tubing with 1/4" flare nut connection. Tubing not included with valve. Maximum tightening torque on flare nut is 15 in-lbs.
- See Metrex datasheet 50M-366 for available capillary assemblies for connecting the valve.
- Do not disassemble actuator. There are no user serviceable parts inside the actuator.

GENERAL DESCRIPTION

- The 565P series valves are high water pressure, direct acting, modulating water regulating valves utilizing internal diaphragm construction to give a smooth, well balanced action. The pressure-balanced design assures fast response to changes in refrigerant pressure and protection against both gradual and sudden water pressure changes. All water pressure boundaries are o-ring sealed for leak-proof, set & forget reliability. The 565P series is rated at 650 PSI refrigerant pressure for R410a service.

ADJUSTMENT

- All valve sizes are multi-range valves applicable to various refrigerants. The refrigerant pressure at which the valve begins to open can be adjusted as shown in Table II. An approximate increase in refrigerant pressure is required to fully open the valve is also listed in Table II.

To adjust condensing head pressure, use wrench and turn adjusting screw on top of the spring housing. Turn counter clockwise to raise the opening point and clockwise to lower.

MANUAL FLUSHING

- All valves may be manually flushed by inserting a screwdriver in openings at opposite sides of the spring housing and lifting the lower spring plate to open the valve. The valve adjustment is not affected by manual flushing.

