

## SELECTION CRITERIA

- Seawater service
- 115 VAC, 60Hz, 1 PH, 2.5A
- Shock Qualified (MIL-S-901D)
- Vibration Qualified (MIL-STD-167)
- Cv = 156, 110 or 78
- Manual Override
- MIL-PRF-20042 Flanges (250 Pound)
- ANSI Flanges available
- 2-Way configuration
- 4" NPS
- 220 PSI water pressure rating
- 330 PSI proof pressure

## CONSTRUCTION DETAILS

- Monel internals
- Buna-N seals
- Body material: Bronze (ASTM B61)

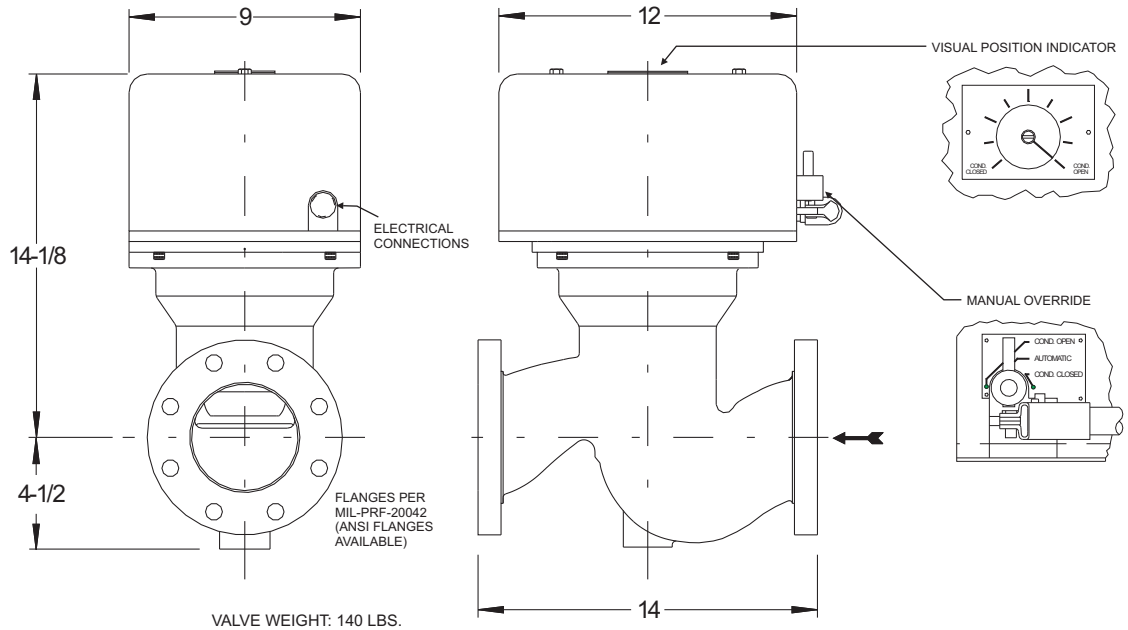

## FLOW DATA

DIFFERENTIAL PRESSURE VS FLOW  
(with valve full open)

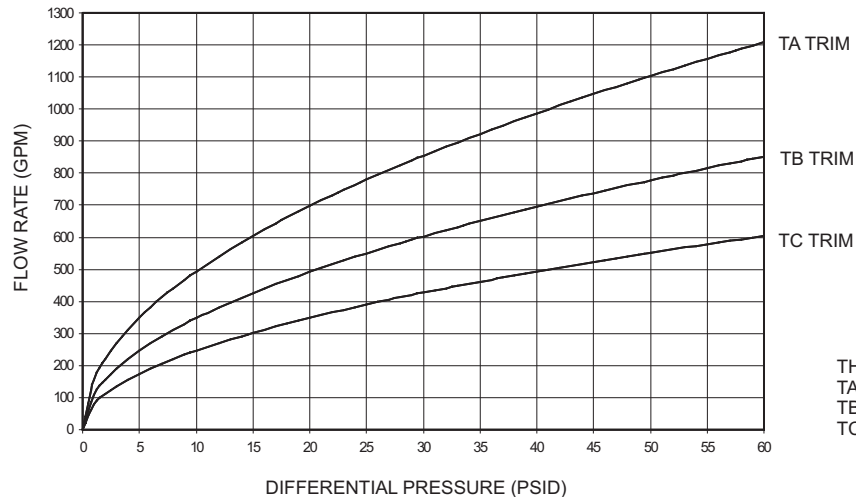

THREE TRIM SELECTIONS:  
TA Trim: Cv=156  
TB Trim: Cv=110  
TC Trim: Cv=78

## HEAD PRESSURE REGULATOR TYPICAL APPLICATION

- Typically used to modulate the cooling water through a condenser in response to a control signal from the condenser. Refrigerant head pressure is maintained over a wide range of operating conditions for a maximum system operating efficiency.

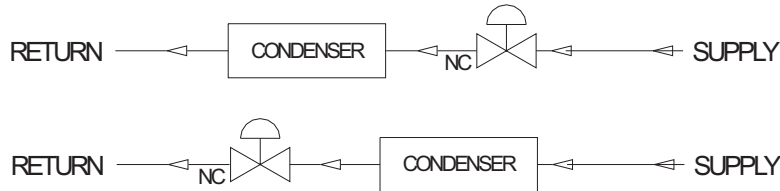

## INSTALLATION & OPERATION

Valves must be mounted with the valve stem vertical in a horizontal flow line. Consider the accessibility of the electrical connections and the manual override. Connect wiring per Wiring Diagram. Actuator provides NPT conduit entry points.

Referring to the Wiring Diagram, 115 VAC voltage to terminals 1 and 2 acts to close the valve while voltage to terminals 1 and 3 acts to open the valve. Referring to the hydraulic schematic, movement of the valve stem is effected by a compact self-contained hydraulic unit and hydraulic cylinder. The hydraulic unit is bi-directional and incorporates load check valves that prevent drifting after actuation to maintain precise positioning. Actuation in the open direction acts to retract the hydraulic cylinder while actuation in the closed direction acts to extend the cylinder. A bi-directional differential pressure switch acts as a travel limit switch in both directions of stem travel. It cuts power on an increase in pressure differential between the

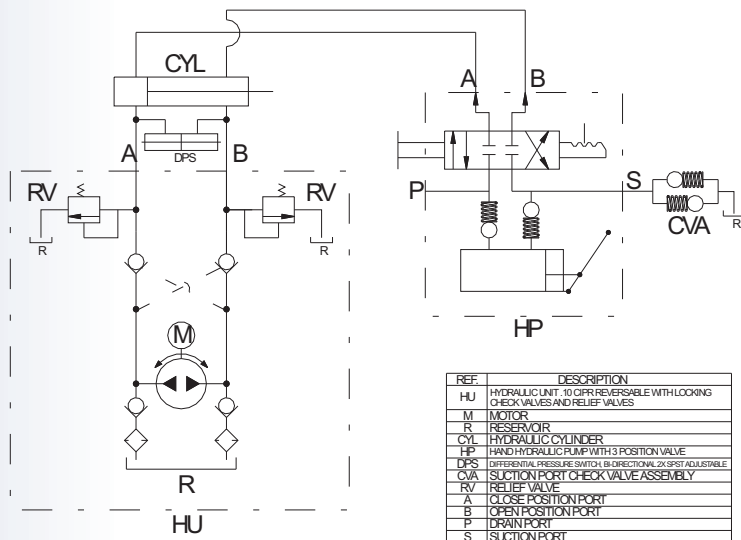
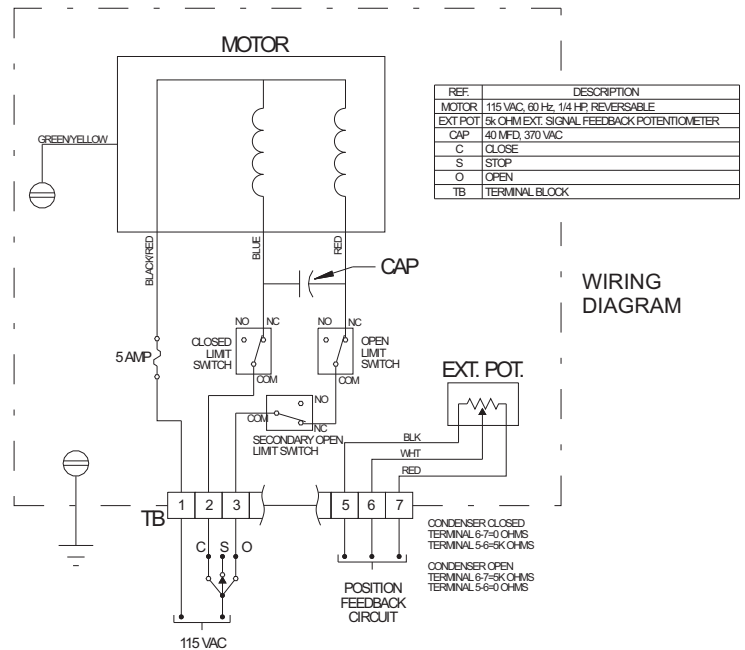

HYDRAULIC SCHEMATIC

cylinder high side and low side for each direction of travel when the limit of travel is reached. Power in the stopped direction is interrupted until valve stem is moved from this position by actuation in the opposite direction. The hydraulic unit operates at a nearly constant displacement rate in both directions independent of load and the hydraulic cylinder is sized for full-stroke times of approximately 20 seconds in either direction. A hand pump with handle is provided for manual operation. It incorporates a three position valve for condenser "open" or condenser "closed" direction or "automatic operation". The hydraulic unit incorporates relief valves so that it will not be damaged by over pressurization while using the hand pump after the valve has reached the limits of travel in either direction. The actuator is equipped with a position indicator showing open, closed, and intermediate valve positions. A 5K ohm potentiometer (tolerance = ±10%) is provided to supply valve position indication at a remote location.