

SELECTION CRITERIA

- Fresh water use
- Direct acting
- R-410a service
- Flanged end connections
- 3-Way configuration
- 2" & 2-1/2" sizes
- 150 PSI water pressure rating
- 650 PSI refrigerant pressure rating

CONSTRUCTION DETAILS

- Brass & Stainless Steel internals
- Buna-N diaphragms & seals
- Body material: See Table II
- Flange: See Table II

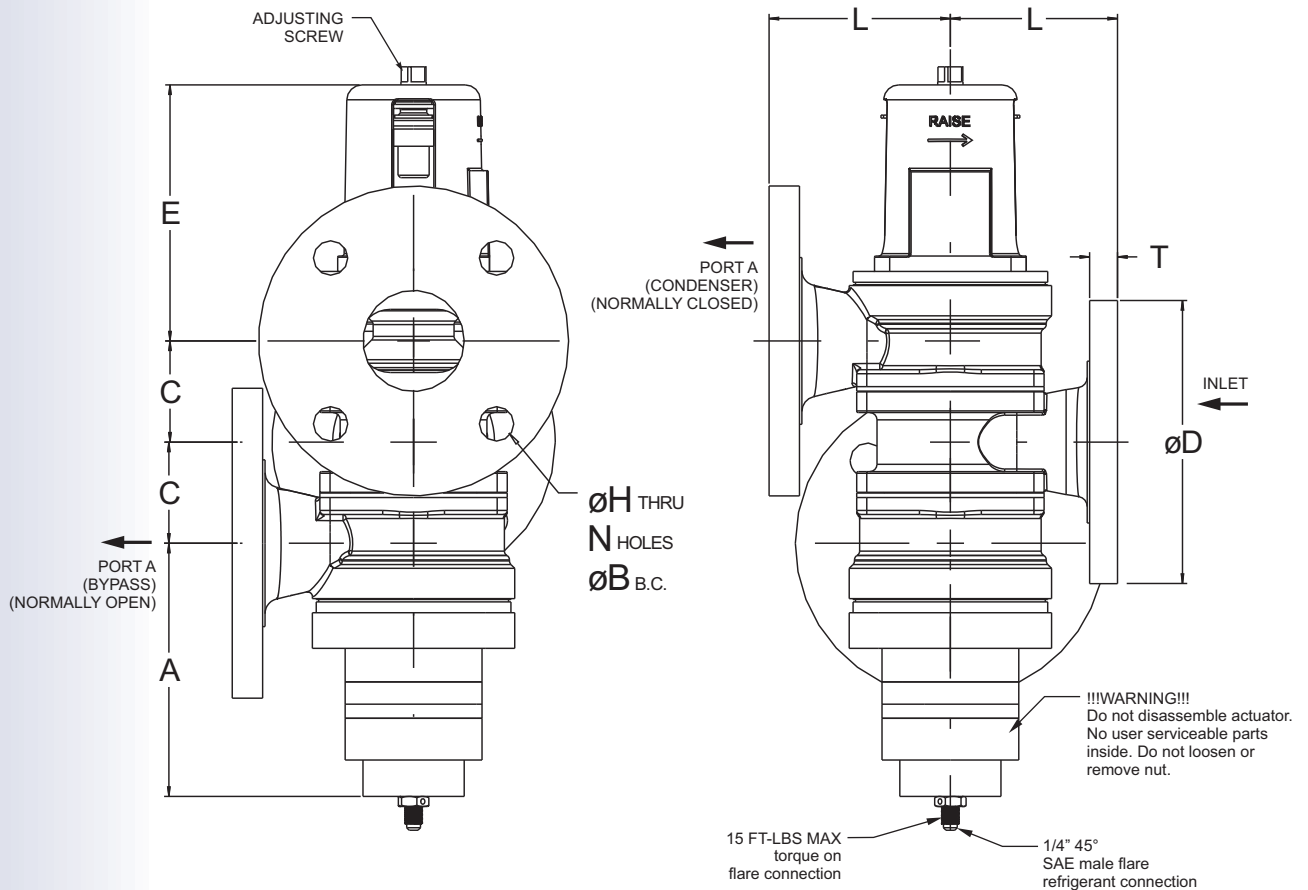

*NOTE: Normally closed ports open on pressure increase, normally open ports close on pressure increase.

VALVE SIZING CHART

VALVE PART NUMBER	VALVE SIZE	C _v	VALVE DIMENSIONS			
			A ±.13	C ±.06	E ±.13	L ±.06
965P-200-FL-3W	2"	26	6.00	1.94	5.91	3.63
965P-250-FL-3W	2-1/2"	37	6.25	2.50	6.32	4.13

All dimensions are in inches

ORDERING INFORMATION

- Use the valve sizing chart on the preceding page, tables, and charts below to determine the complete part number.

BASIC PART NO.: 965P - - FL -3W

VALVE SIZING CHART
(200 or 250)

TABLE II (1 or 2)

VALVE CONFIGURATION
(LL, LR, UL, UR, LL/UR or LR/UL)

EXAMPLE:

965P-250-ULFL1-3W

Size=2-1/2

Upper port (Port A) to the left configuration

ANSI B16.1 Cast iron body

VALVE FLOW DATA

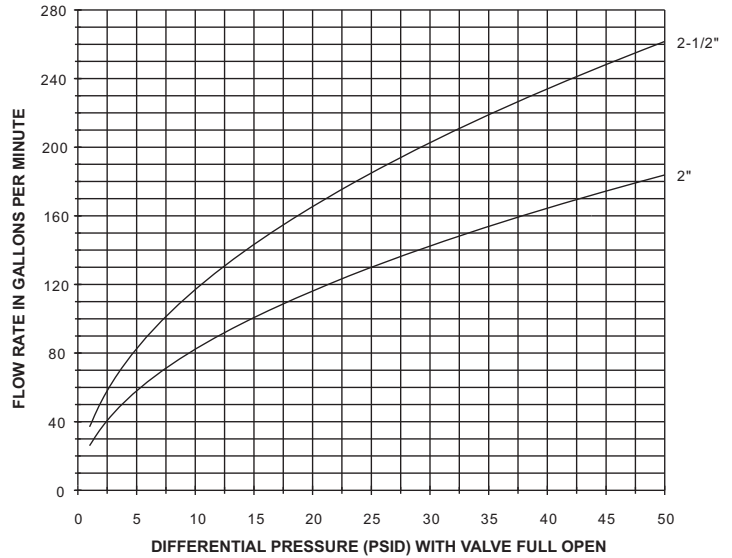

PRESSURE RANGE ADJUSTMENT

- The refrigerant pressure range at which the valve begins to open can be adjusted from approximately 100 to 340 PSIG. An increase in refrigerant pressure of approximately 65-70 PSIG is required to fully open Port A.

TABLE II

ASSEMBLY NUMBER	MATERIAL	FLANGE SPECIFICATION	DESIGN PRESS.	PROOF PRESS.	FLANGE DIMENSIONS				
					N	H	B	D	T
-200_FL1-	CAST IRON	ANSI B16.1 CLASS 125 LB.	150 PSI	225 PSI	4	0.75"	4.75"	6.00"	0.50"
-200_FL2-	BRONZE	ANSI B16.24 CLASS 150 LB.	150 PSI	225 PSI	4	0.75"	4.75"	6.00"	0.50"
-250_FL1-	CAST IRON	ANSI B16.1 CLASS 125 LB.	150 PSI	225 PSI	4	0.75"	5.50"	7.00"	0.69"
-250_FL2-	BRONZE	ANSI B16.24 CLASS 150 LB.	150 PSI	225 PSI	4	0.75"	5.50"	7.00"	0.56"

VALVE CONFIGURATION

LL
LOWER PORT TO THE LEFT

LR
LOWER PORT TO THE RIGHT
(DEFAULT)

UL
UPPER PORT TO THE LEFT

UR
UPPER PORT TO THE RIGHT

LL/UR
LOWER PORT LEFT/
UPPER PORT RIGHT

LR/UL
LOWER PORT RIGHT/
UPPER PORT LEFT

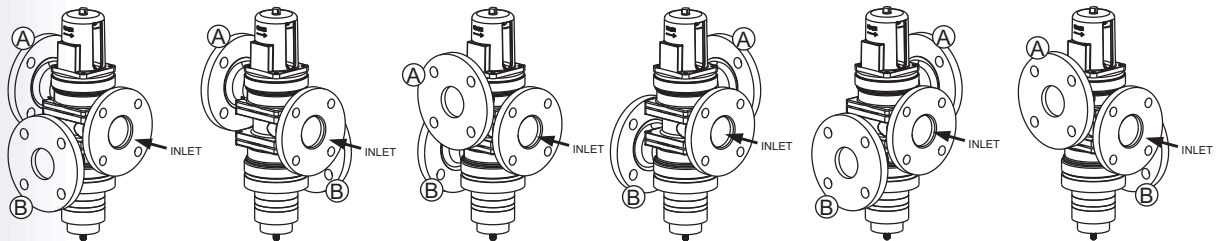

3-WAY HEAD PRESSURE REGULATOR TYPICAL APPLICATION

- Typically used to modulate the cooling water through a condenser in response to a pressure signal from the condenser. Refrigerant head pressure is maintained over a wide range of operating conditions for a maximum system operating efficiency.

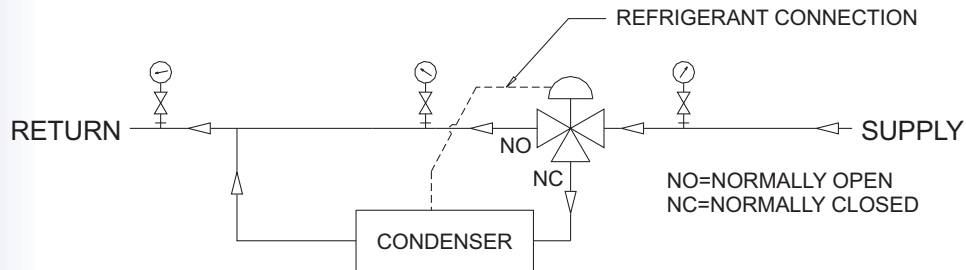

INSTALLATION INSTRUCTIONS

- Valves can be mounted in any position without affecting performance. However, for ease of adjustment consider the accessibility of the adjusting screw.
- Connect the incoming water line to the valve inlet. Direction of water flow is indicated by the arrow cast on the side of the valve body. Port A (normally closed) is typically piped to the condenser inlet. Port B should be piped to bypass the condenser.
- Connect refrigerant connection capillary to refrigerant pressure connection on the condenser.
- See Metrex datasheet 50M-366 for available capillary assemblies for connecting the valve.
- Do not disassemble actuator. There are no user serviceable parts inside the actuator.

GENERAL DESCRIPTION

- The 965 series valves are direct acting, modulating water regulating valves utilizing a diaphragm construction to give smooth, well balanced action. The pressure-balanced design and low frictional coefficient of the diaphragms assure fast response to changes in refrigerant pressure and protection against both gradual and sudden water pressure changes. All sliding parts and adjustment springs are isolated from the water flow by the leak proof diaphragms. The actuator is designed for use with R-410a and is rated at a full 650 PSIG.

ADJUSTMENT

- All valves in 2" and 2-1/2" sizes are suitable for R-410a service. The refrigerant pressure at which the Port A begins to open (and Port B begins to close) can be adjusted between 100 and 340. A 65-70 PSI increase of refrigerant pressure is required to fully open Port A (fully shut Port B).

To adjust condensing head pressure, use the adjusting screw on top of the spring housing. Turn counter clockwise to raise the opening point (raise head pressure). Turn clockwise to lower the opening point (lower head pressure).

MANUAL OVERRIDE

- All valves may be manually flushed by inserting a screwdriver in openings at opposite sides of the spring housing and lifting the lower spring plate to open the valve. The valve adjustment is not affected by manual flushing.

